

# Graduate Aptitude Test in Engineering 2017

**Question Paper Name:** Mechanical Engineering 4th feb 2017 session 2  
**Subject Name:** Mechanical Engineering  
**Duration:** 180  
**Total Marks:** 100



## Organizing Institute: Indian Institute of Technology Roorkee



**Question Number : 1****Correct : 1 Wrong : 0**

Two coins are tossed simultaneously. The probability (upto two decimal points accuracy) of getting at least one head is \_\_\_\_\_

**Question Number : 2****Correct : 1 Wrong : 0**

The divergence of the vector  $-y\mathbf{i} + x\mathbf{j}$  is \_\_\_\_\_

**Question Number : 3****Correct : 1 Wrong : 0**

The determinant of a  $2 \times 2$  matrix is 50. If one eigenvalue of the matrix is 10, the other eigenvalue is \_\_\_\_\_

**Question Number : 4****Correct : 1 Wrong : -0.33**

A sample of 15 data is as follows: 17, 18, 17, 17, 13, 18, 5, 5, 6, 7, 8, 9, 20, 17, 3. The mode of the data is

- (A) 4                      (B) 13                      (C) 17                      (D) 20

**Question Number : 5****Correct : 1 Wrong : -0.33**

The Laplace transform of  $te^t$  is

- (A)  $\frac{s}{(s+1)^2}$                       (B)  $\frac{1}{(s-1)^2}$                       (C)  $\frac{1}{(s+1)^2}$                       (D)  $\frac{s}{s-1}$

**Question Number : 6****Correct : 1 Wrong : -0.33**

A mass  $m$  is attached to two identical springs having spring constant  $k$  as shown in the figure. The natural frequency  $\omega$  of this single degree of freedom system is

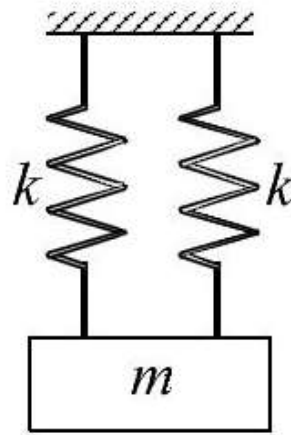

(A)  $\sqrt{\frac{2k}{m}}$

(B)  $\sqrt{\frac{k}{m}}$

(C)  $\sqrt{\frac{k}{2m}}$

(D)  $\sqrt{\frac{4k}{m}}$

**Question Number : 7****Correct : 1 Wrong : 0**

The state of stress at a point is  $\sigma_x = \sigma_y = \sigma_z = \tau_{xz} = \tau_{zx} = \tau_{yz} = \tau_{zy} = 0$  and  $\tau_{xy} = \tau_{yx} = 50$  MPa. The maximum normal stress (in MPa) at that point is \_\_\_\_\_

**Question Number : 8****Correct : 1 Wrong : 0**

For a loaded cantilever beam of uniform cross-section, the bending moment (in N·mm) along the length is  $M(x) = 5x^2 + 10x$ , where  $x$  is the distance (in mm) measured from the free end of the beam. The magnitude of shear force (in N) in the cross-section at  $x = 10$  mm is \_\_\_\_\_

**Question Number : 9****Correct : 1 Wrong : -0.33**

A cantilever beam of length  $L$  and flexural modulus  $EI$  is subjected to a point load  $P$  at the free end. The elastic strain energy stored in the beam due to bending (neglecting transverse shear) is

(A)  $\frac{P^2 L^3}{6EI}$

(B)  $\frac{P^2 L^3}{3EI}$

(C)  $\frac{PL^3}{3EI}$

(D)  $\frac{PL^3}{6EI}$

**Question Number : 10****Correct : 1 Wrong : 0**

A steel bar is held by two fixed supports as shown in the figure and is subjected to an increase of temperature  $\Delta T=100\text{ }^\circ\text{C}$ . If the coefficient of thermal expansion and Young's modulus of elasticity of steel are  $11\times 10^{-6}/^\circ\text{C}$  and 200 GPa, respectively, the magnitude of thermal stress (in MPa) induced in the bar is \_\_\_\_\_

**Question Number : 11****Correct : 1 Wrong : 0**

A machine component made of a ductile material is subjected to a variable loading with  $\sigma_{\min} = -50\text{ MPa}$  and  $\sigma_{\max} = 50\text{ MPa}$ . If the corrected endurance limit and the yield strength for the material are  $\sigma'_e = 100\text{ MPa}$  and  $\sigma_y = 300\text{ MPa}$ , respectively, the factor of safety is \_\_\_\_\_

**Question Number : 12****Correct : 1 Wrong : 0**

In a slider-crank mechanism, the lengths of the crank and the connecting rod are 100 mm and 160 mm, respectively. The crank is rotating with an angular velocity of 10 radian/s counter-clockwise. The magnitude of linear velocity (in m/s) of the piston at the instant corresponding to the configuration shown in the figure is \_\_\_\_\_

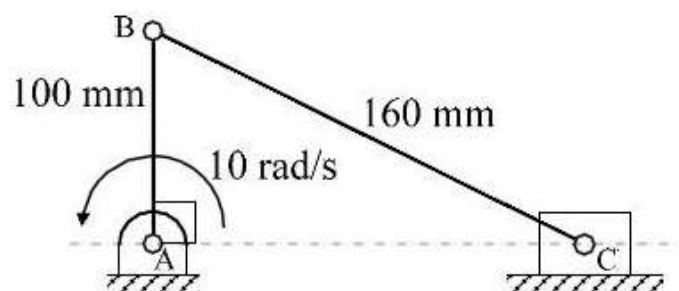

**Question Number : 13****Correct : 1 Wrong : -0.33**

Which one of the following statements is **TRUE**?

- (A) Both Pelton and Francis turbines are impulse turbines.
- (B) Francis turbine is a reaction turbine but Kaplan turbine is an impulse turbine.
- (C) Francis turbine is an axial-flow reaction turbine.
- (D) Kaplan turbine is an axial-flow reaction turbine.

**Question Number : 14****Correct : 1 Wrong : -0.33**

A mass  $m$  of a perfect gas at pressure  $p_1$  and volume  $V_1$  undergoes an isothermal process. The final pressure is  $p_2$  and volume is  $V_2$ . The work done on the system is considered positive. If  $R$  is the gas constant and  $T$  is the temperature, then the work done in the process is

- (A)  $p_1 V_1 \ln \frac{V_2}{V_1}$
- (B)  $-p_1 V_1 \ln \frac{p_1}{p_2}$
- (C)  $RT \ln \frac{V_2}{V_1}$
- (D)  $-mRT \ln \frac{p_2}{p_1}$

**Question Number : 15****Correct : 1 Wrong : -0.33**

If a mass of moist air contained in a closed metallic vessel is heated, then its

- (A) relative humidity decreases
- (B) relative humidity increases
- (C) specific humidity increases
- (D) specific humidity decreases

**Question Number : 16****Correct : 1 Wrong : -0.33**

For the stability of a floating body the

- (A) centre of buoyancy must coincide with the centre of gravity
- (B) centre of buoyancy must be above the centre of gravity
- (C) centre of gravity must be above the centre of buoyancy
- (D) metacentre must be above the centre of gravity

**Question Number : 17****Correct : 1 Wrong : -0.33**

Consider a laminar flow at zero incidence over a flat plate. The shear stress at the wall is denoted by  $\tau_w$ . The axial positions  $x_1$  and  $x_2$  on the plate are measured from the leading edge in the direction of flow. If  $x_2 > x_1$ , then

(A)  $\tau_w|_{x_1} = \tau_w|_{x_2} = 0$

(B)  $\tau_w|_{x_1} = \tau_w|_{x_2} \neq 0$

(C)  $\tau_w|_{x_1} > \tau_w|_{x_2}$

(D)  $\tau_w|_{x_1} < \tau_w|_{x_2}$

**Question Number : 18****Correct : 1 Wrong : 0**

The heat loss from a fin is 6 W. The effectiveness and efficiency of the fin are 3 and 0.75, respectively. The heat loss (in W) from the fin, keeping the entire fin surface at base temperature, is \_\_\_\_\_

**Question Number : 19****Correct : 1 Wrong : -0.33**

The emissive power of a blackbody is  $P$ . If its absolute temperature is doubled, the emissive power becomes

(A)  $2P$

(B)  $4P$

(C)  $8P$

(D)  $16P$

**Question Number : 20****Correct : 1 Wrong : -0.33**

Which one of the following statements is **TRUE** for the ultrasonic machining (USM) process?

(A) In USM, the tool vibrates at subsonic frequency.

(B) USM does not employ magnetostrictive transducer.

(C) USM is an excellent process for machining ductile materials.

(D) USM often uses a slurry comprising abrasive-particles and water.

**Question Number : 21****Correct : 1 Wrong : -0.33**

The crystal structure of aluminium is

(A) body-centred cubic

(B) face-centred cubic

(C) close-packed hexagonal

(D) body-centred tetragonal

**Question Number : 22****Correct : 1 Wrong : 0**

Given the atomic weight of Fe is 56 and that of C is 12, the weight percentage of carbon in cementite ( $\text{Fe}_3\text{C}$ ) is \_\_\_\_\_

**Question Number : 23****Correct : 1 Wrong : -0.33**

For a single server with Poisson arrival and exponential service time, the arrival rate is 12 per hour. Which one of the following service rates will provide a steady state finite queue length?

- (A) 6 per hour      (B) 10 per hour      (C) 12 per hour      (D) 24 per hour

**Question Number : 24****Correct : 1 Wrong : 0**

The standard deviation of linear dimensions P and Q are  $3 \mu\text{m}$  and  $4 \mu\text{m}$ , respectively. When assembled, the standard deviation (in  $\mu\text{m}$ ) of the resulting linear dimension (P+Q) is \_\_\_\_\_

**Question Number : 25****Correct : 1 Wrong : -0.33**

It is desired to make a product having T-shaped cross-section from a rectangular aluminium block. Which one of the following processes is expected to provide the highest strength of the product?

- (A) Welding      (B) Casting      (C) Metal forming      (D) Machining

**Question Number : 26****Correct : 2 Wrong : 0**

The surface integral  $\iint_S \mathbf{F} \cdot \mathbf{n} \, dS$  over the surface  $S$  of the sphere  $x^2 + y^2 + z^2 = 9$ , where

$\mathbf{F} = (x + y)\mathbf{i} + (x + z)\mathbf{j} + (y + z)\mathbf{k}$  and  $\mathbf{n}$  is the unit outward surface normal, yields \_\_\_\_\_

**Question Number : 27****Correct : 2 Wrong : 0**

Consider the differential equation  $3y''(x) + 27y(x) = 0$  with initial conditions  $y(0) = 0$  and  $y'(0) = 2000$ . The value of  $y$  at  $x = 1$  is \_\_\_\_\_

**Question Number : 28****Correct : 2 Wrong : 0**

Consider the matrix  $\mathbf{A} = \begin{bmatrix} 50 & 70 \\ 70 & 80 \end{bmatrix}$  whose eigenvectors corresponding to eigenvalues  $\lambda_1$  and  $\lambda_2$  are  $\mathbf{x}_1 = \begin{bmatrix} 70 \\ \lambda_1 - 50 \end{bmatrix}$  and  $\mathbf{x}_2 = \begin{bmatrix} \lambda_2 - 80 \\ 70 \end{bmatrix}$ , respectively. The value of  $\mathbf{x}_1^T \mathbf{x}_2$  is \_\_\_\_\_

**Question Number : 29****Correct : 2 Wrong : -0.66**

If  $f(z) = (x^2 + ay^2) + ibxy$  is a complex analytic function of  $z = x + iy$ , where  $i = \sqrt{-1}$ , then  
 (A)  $a = -1, b = -1$       (B)  $a = -1, b = 2$       (C)  $a = 1, b = 2$       (D)  $a = 2, b = 2$

**Question Number : 30****Correct : 2 Wrong : 0**

Block 2 slides outward on link 1 at a uniform velocity of 6 m/s as shown in the figure. Link 1 is rotating at a constant angular velocity of 20 radian/s counterclockwise. The magnitude of the total acceleration (in  $\text{m/s}^2$ ) of point P of the block with respect to fixed point O is \_\_\_\_\_

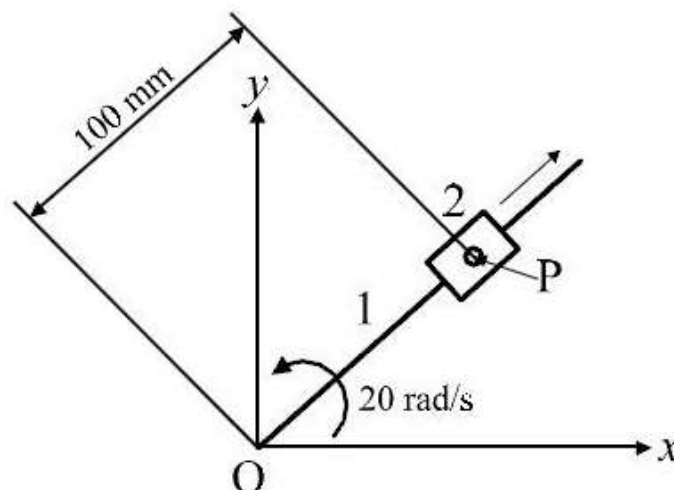

**Question Number : 31****Correct : 2 Wrong : 0**

The radius of gyration of a compound pendulum about the point of suspension is 100 mm. The distance between the point of suspension and the centre of mass is 250 mm. Considering the acceleration due to gravity as  $9.81 \text{ m/s}^2$ , the natural frequency (in radian/s) of the compound pendulum is \_\_\_\_\_

**Question Number : 32****Correct : 2 Wrong : 0**

A gear train shown in the figure consists of gears P, Q, R and S. Gear Q and gear R are mounted on the same shaft. All the gears are mounted on parallel shafts and the number of teeth of P, Q, R and S are 24, 45, 30 and 80, respectively. Gear P is rotating at 400 rpm. The speed (in rpm) of the gear S is \_\_\_\_\_

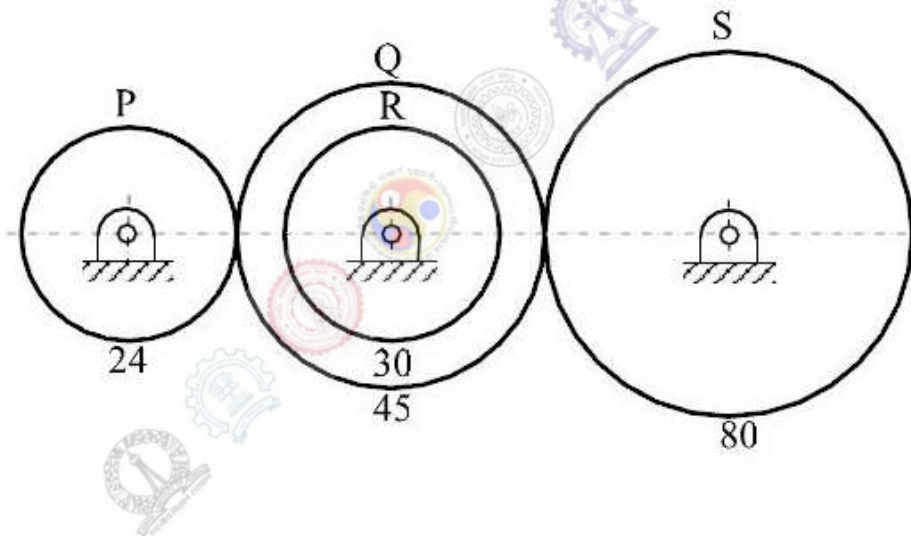
**Question Number : 33****Correct : 2 Wrong : 0**

A helical compression spring made of a wire of circular cross-section is subjected to a compressive load. The maximum shear stress induced in the cross-section of the wire is 24 MPa. For the same compressive load, if both the wire diameter and the mean coil diameter are doubled, the maximum shear stress (in MPa) induced in the cross-section of the wire is \_\_\_\_\_

**Question Number : 34**

**Correct : 2 Wrong : 0**

Three masses are connected to a rotating shaft supported on bearings A and B as shown in the figure. The system is in a space where the gravitational effect is absent. Neglect the mass of shaft and rods connecting the masses. For  $m_1 = 10$  kg,  $m_2 = 5$  kg and  $m_3 = 2.5$  kg and for a shaft angular speed of 1000 radian/s, the magnitude of the bearing reaction (in N) at location B is \_\_\_\_\_

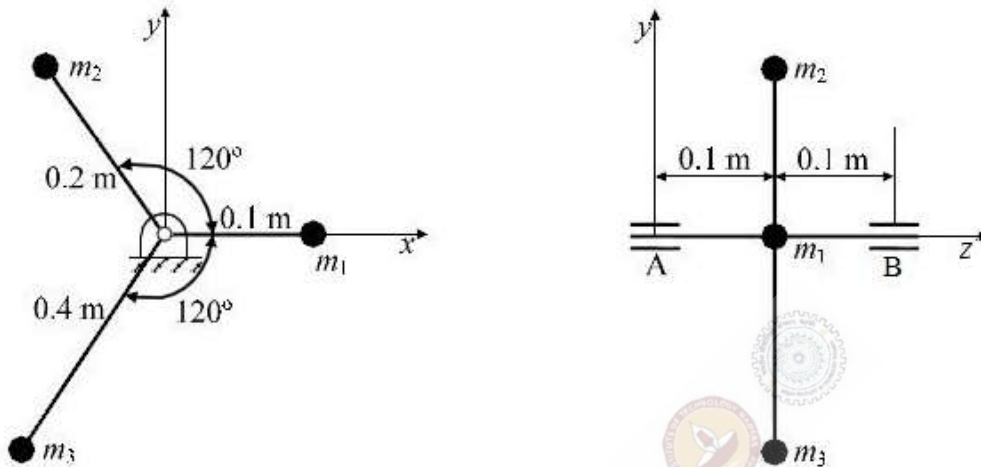

**Question Number : 35**

**Correct : 2 Wrong : -0.66**

A steel plate, connected to a fixed channel using three identical bolts A, B and C, carries a load of 6 kN as shown in the figure. Considering the effect of direct load and moment, the magnitude of resultant shear force (in kN) on bolt C is

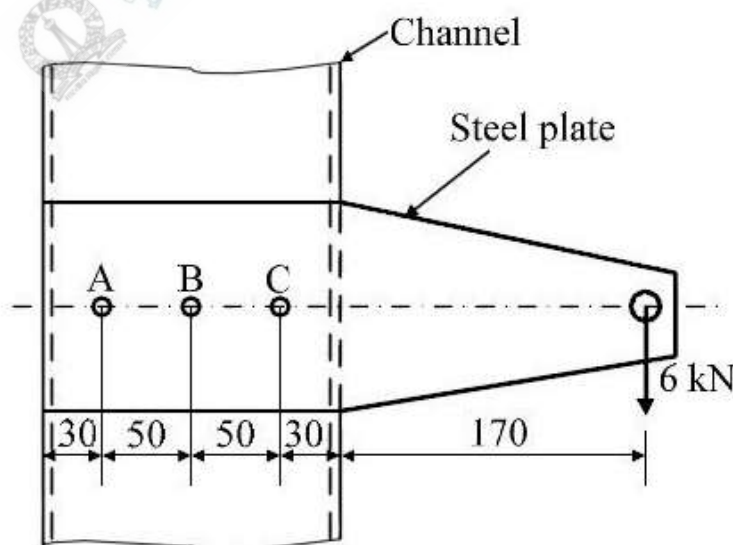

All dimensions are in mm.

(A) 13

(B) 15

(C) 17

(D) 30

**Question Number : 36****Correct : 2 Wrong : 0**

A single-plate clutch has a friction disc with inner and outer radii of 20 mm and 40 mm, respectively. The friction lining in the disc is made in such a way that the coefficient of friction  $\mu$  varies radially as  $\mu = 0.01r$ , where  $r$  is in mm. The clutch needs to transmit a friction torque of 18.85 kN·mm. As per uniform pressure theory, the pressure (in MPa) on the disc is \_\_\_\_\_

**Question Number : 37****Correct : 2 Wrong : -0.66**

The principal stresses at a point in a critical section of a machine component are  $\sigma_1 = 60$  MPa,  $\sigma_2 = 5$  MPa and  $\sigma_3 = -40$  MPa. For the material of the component, the tensile yield strength is  $\sigma_y = 200$  MPa. According to the maximum shear stress theory, the factor of safety is

(A) 1.67

(B) 2.00

(C) 3.60

(D) 4.00

**Question Number : 38****Correct : 2 Wrong : 0**

The rod PQ of length  $L = \sqrt{2}$  m, and uniformly distributed mass of  $M = 10$  kg, is released from rest at the position shown in the figure. The ends slide along the frictionless faces OP and OQ. Assume acceleration due to gravity,  $g = 10$  m/s<sup>2</sup>. The mass moment of inertia of the rod about its centre of mass and an axis perpendicular to the plane of the figure is  $(ML^2/12)$ . At this instant, the magnitude of angular acceleration (in radian/s<sup>2</sup>) of the rod is \_\_\_\_\_

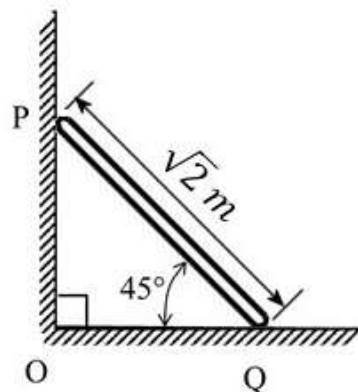

**Question Number : 39**

**Correct : 2 Wrong : 0**

The arrangement shown in the figure measures the velocity  $V$  of a gas of density  $1 \text{ kg/m}^3$  flowing through a pipe. The acceleration due to gravity is  $9.81 \text{ m/s}^2$ . If the manometric fluid is water (density  $1000 \text{ kg/m}^3$ ) and the velocity  $V$  is  $20 \text{ m/s}$ , the differential head  $h$  (in mm) between the two arms of the manometer is \_\_\_\_\_

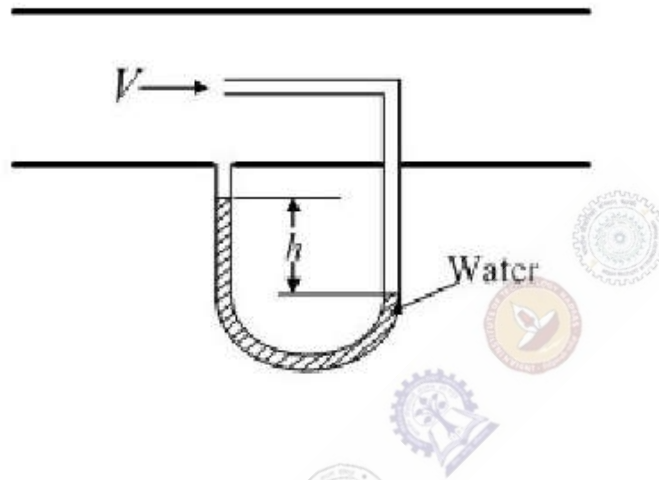

**Question Number : 40**

**Correct : 2 Wrong : 0**

A  $60 \text{ mm}$ -diameter water jet strikes a plate containing a hole of  $40 \text{ mm}$  diameter as shown in the figure. Part of the jet passes through the hole horizontally, and the remaining is deflected vertically. The density of water is  $1000 \text{ kg/m}^3$ . If velocities are as indicated in the figure, the magnitude of horizontal force (in N) required to hold the plate is \_\_\_\_\_

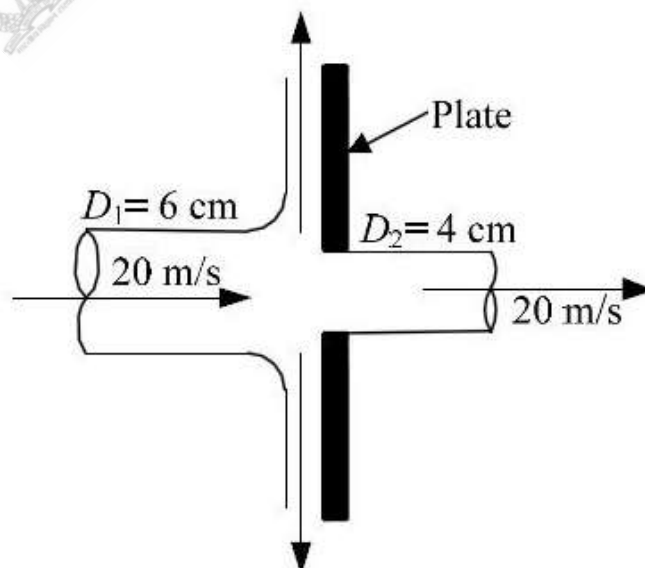

**Question Number : 41****Correct : 2 Wrong : 0**

For the laminar flow of water over a sphere, the drag coefficient  $C_F$  is defined as  $C_F = F / (\rho U^2 D^2)$ , where  $F$  is the drag force,  $\rho$  is the fluid density,  $U$  is the fluid velocity and  $D$  is the diameter of the sphere. The density of water is  $1000 \text{ kg/m}^3$ . When the diameter of the sphere is  $100 \text{ mm}$  and the fluid velocity is  $2 \text{ m/s}$ , the drag coefficient is  $0.5$ . If water now flows over another sphere of diameter  $200 \text{ mm}$  under dynamically similar conditions, the drag force (in  $\text{N}$ ) on this sphere is \_\_\_\_\_

**Question Number : 42****Correct : 2 Wrong : 0**

In the Rankine cycle for a steam power plant the turbine entry and exit enthalpies are  $2803 \text{ kJ/kg}$  and  $1800 \text{ kJ/kg}$ , respectively. The enthalpies of water at pump entry and exit are  $121 \text{ kJ/kg}$  and  $124 \text{ kJ/kg}$ , respectively. The specific steam consumption (in  $\text{kg/kW.h}$ ) of the cycle is \_\_\_\_\_

**Question Number : 43****Correct : 2 Wrong : -0.66**

A calorically perfect gas (specific heat at constant pressure  $1000 \text{ J/kg}\cdot\text{K}$ ) enters and leaves a gas turbine with the same velocity. The temperatures of the gas at turbine entry and exit are  $1100 \text{ K}$  and  $400 \text{ K}$ , respectively. The power produced is  $4.6 \text{ MW}$  and heat escapes at the rate of  $300 \text{ kJ/s}$  through the turbine casing. The mass flow rate of the gas (in  $\text{kg/s}$ ) through the turbine is

(A) 6.14

(B) 7.00

(C) 7.50

(D) 8.00

**Question Number : 44****Correct : 2 Wrong : 0**

One  $\text{kg}$  of an ideal gas (gas constant  $R = 287 \text{ J/kg}\cdot\text{K}$ ) undergoes an irreversible process from state-1 ( $1 \text{ bar}$ ,  $300 \text{ K}$ ) to state-2 ( $2 \text{ bar}$ ,  $300 \text{ K}$ ). The change in specific entropy ( $s_2 - s_1$ ) of the gas (in  $\text{J/kg}\cdot\text{K}$ ) in the process is \_\_\_\_\_



**Question Number : 49**

**Correct : 2 Wrong : 0**

A project starts with activity A and ends with activity F. The precedence relation and durations of the activities are as per the following table:

Activity	Immediate predecessor	Duration (days)
A	–	4
B	A	3
C	A	7
D	B	14
E	C	4
F	D, E	9

The minimum project completion time (in days) is \_\_\_\_\_

**Question Number : 50**

**Correct : 2 Wrong : -0.66**

A rod of length 20 mm is stretched to make a rod of length 40 mm. Subsequently, it is compressed to make a rod of final length 10 mm. Consider the longitudinal tensile strain as positive and compressive strain as negative. The total true longitudinal strain in the rod is

- (A)  $-0.5$                       (B)  $-0.69$                       (C)  $-0.75$                       (D)  $-1.0$

**Question Number : 51**

**Correct : 2 Wrong : 0**

Maximize  $Z = 5x_1 + 3x_2$ ,

subject to

$$x_1 + 2x_2 \leq 10,$$

$$x_1 - x_2 \leq 8,$$

$$x_1, x_2 \geq 0.$$

In the starting Simplex tableau,  $x_1$  and  $x_2$  are non-basic variables and the value of  $Z$  is zero. The value of  $Z$  in the next Simplex tableau is \_\_\_\_\_

**Question Number : 52****Correct : 2 Wrong : 0**

A strip of 120 mm width and 8 mm thickness is rolled between two 300 mm-diameter rolls to get a strip of 120 mm width and 7.2 mm thickness. The speed of the strip at the exit is 30 m/min. There is no front or back tension. Assuming uniform roll pressure of 200 MPa in the roll bite and 100% mechanical efficiency, the minimum total power (in kW) required to drive the two rolls is \_\_\_\_\_

**Question Number : 53****Correct : 2 Wrong : 0**

A cylindrical pin of  $25^{+0.020}_{+0.010}$  mm diameter is electroplated. Plating thickness is  $2.0^{\pm 0.005}$  mm. Neglecting the gauge tolerance, the diameter (in mm, up to 3 decimal points accuracy) of the GO ring gauge to inspect the plated pin is \_\_\_\_\_

**Question Number : 54****Correct : 2 Wrong : -0.66**

During the turning of a 20 mm-diameter steel bar at a spindle speed of 400 rpm, a tool life of 20 minute is obtained. When the same bar is turned at 200 rpm, the tool life becomes 60 minute. Assume that Taylor's tool life equation is valid. When the bar is turned at 300 rpm, the tool life (in minute) is approximately

(A) 25

(B) 32

(C) 40

(D) 50

**Question Number : 55****Correct : 2 Wrong : 0**

In an orthogonal machining with a tool of  $9^\circ$  orthogonal rake angle, the uncut chip thickness is 0.2 mm. The chip thickness fluctuates between 0.25 mm and 0.4 mm. The ratio of the maximum shear angle to the minimum shear angle during machining is \_\_\_\_\_

**Question Number : 56**

**Correct : 1 Wrong : -0.33**

The ways in which this game can be played \_\_\_\_\_ potentially infinite.

- (A) is                      (B) is being                      (C) are                      (D) are being

**Question Number : 57**

**Correct : 1 Wrong : -0.33**

If you choose plan P, you will have to \_\_\_\_\_ plan Q, as these two are mutually \_\_\_\_\_.

- (A) forgo, exclusive                      (B) forget, inclusive  
(C) accept, exhaustive                      (D) adopt, intrusive

**Question Number : 58**

**Correct : 1 Wrong : -0.33**

If  $a$  and  $b$  are integers and  $a - b$  is even, which of the following must always be even?

- (A)  $ab$                       (B)  $a^2 + b^2 + 1$                       (C)  $a^2 + b + 1$                       (D)  $ab - b$

**Question Number : 59**

**Correct : 1 Wrong : -0.33**

A couple has 2 children. The probability that both children are boys if the older one is a boy is

- (A)  $1/4$                       (B)  $1/3$                       (C)  $1/2$                       (D)  $1$

**Question Number : 60**

**Correct : 1 Wrong : -0.33**

P looks at Q while Q looks at R. P is married, R is not. The number of pairs of people in which a married person is looking at an unmarried person is

- (A) 0                      (B) 1                      (C) 2                      (D) Cannot be determined

**Question Number : 61****Correct : 2 Wrong : -0.66**

“If you are looking for a history of India, or for an account of the rise and fall of the British Raj, or for the reason of the cleaving of the subcontinent into two mutually antagonistic parts and the effects this mutilation will have in the respective sections, and ultimately on Asia, you will not find it in these pages; for though I have spent a lifetime in the country, I lived too near the seat of events, and was too intimately associated with the actors, to get the perspective needed for the impartial recording of these matters.”

Which of the following is closest in meaning to ‘cleaving’?

- (A) deteriorating      (B) arguing      (C) departing      (D) splitting

**Question Number : 62****Correct : 2 Wrong : -0.66**

X bullocks and Y tractors take 8 days to plough a field. If we halve the number of bullocks and double the number of tractors, it takes 5 days to plough the same field. How many days will it take X bullocks alone to plough the field?

- (A) 30      (B) 35      (C) 40      (D) 45

**Question Number : 63****Correct : 2 Wrong : -0.66**

There are 4 women P, Q, R, S, and 5 men V, W, X, Y, Z in a group. We are required to form pairs each consisting of one woman and one man. P is not to be paired with Z, and Y must necessarily be paired with someone. In how many ways can 4 such pairs be formed?

- (A) 74      (B) 76      (C) 78      (D) 80

**Question Number : 64****Correct : 2 Wrong : -0.66**

All people in a certain island are either ‘Knights’ or ‘Knaves’ and each person knows every other person’s identity. Knights NEVER lie, and knaves ALWAYS lie.

P says “Both of us are knights”. Q says “None of us are knaves”.

Which one of the following can be logically inferred from the above?

- (A) Both P and Q are knights  
(B) P is a knight; Q is a knave  
(C) Both P and Q are knaves  
(D) The identities of P, Q cannot be determined

In the graph below, the concentration of a particular pollutant in a lake is plotted over (alternate) days of a month in winter (average temperature 10 °C) and a month in summer (average temperature 30 °C).

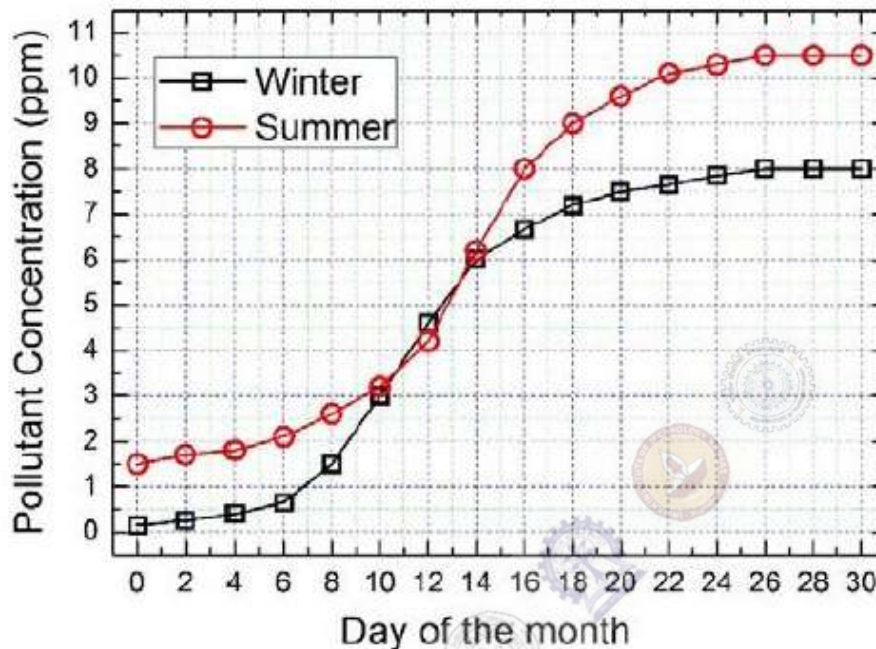

Consider the following statements based on the data shown above:

- i. Over the given months, the difference between the maximum and the minimum pollutant concentrations is the same in both winter and summer.
- ii. There are at least four days in the summer month such that the pollutant concentrations on those days are within 1 ppm of the pollutant concentrations on the corresponding days in the winter month.

Which one of the following options is correct?

- (A) Only i                      (B) Only ii                      (C) Both i and ii                      (D) Neither i nor ii